



STP4N150 STW4N150

N-CHANNEL 1500V - 5Ω - 4A TO-220/TO-247 Very High Voltage PowerMESH™ MOSFET

Table 1: General Features

TYPE	V _{DSS}	R _{DS(on)}	I _D	P _w
STP4N150	1500 V	< 7 Ω	4 A	160 W
STW4N150	1500 V	< 7 Ω	4 A	160 W

- TYPICAL R_{DS(on)} = 5 Ω
- AVALANCHE RUGGEDNESS
- GATE CHARGE MINIMIZED
- VERY LOW INTRINSIC CAPACITANCES
- HIGH SPEED SWITCHING

DESCRIPTION

Using the well consolidated high voltage MESH OVERLAY™ process, STMicroelectronics has designed an advanced family of Power MOSFETs with outstanding performances. The strengthened layout coupled with the Company's proprietary edge termination structure, gives the lowest R_{DS(on)} per area, unrivalled gate charge and switching characteristics.

APPLICATIONS

- SWITCH MODE POWER SUPPLIES

Figure 1: Package

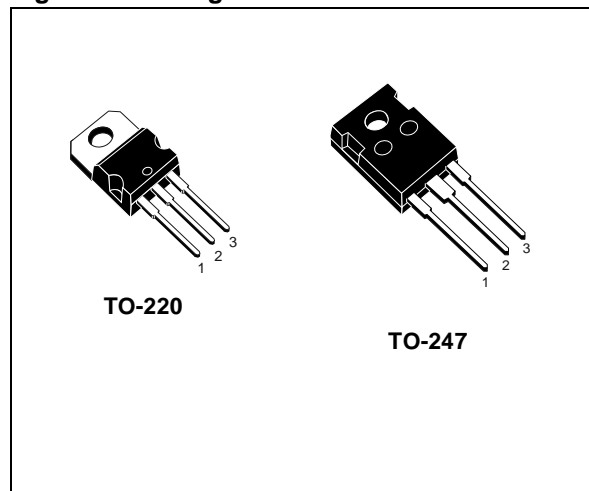

Figure 2: Internal Schematic Diagram

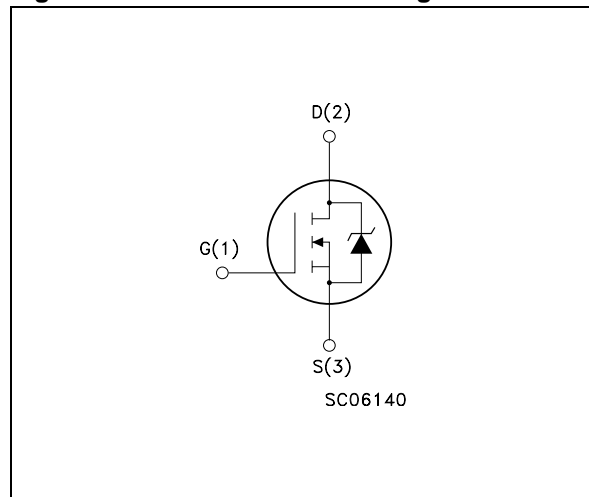

Table 2: Order Codes

SALES TYPE	MARKING	PACKAGE	PACKAGING
STP4N150	P4N150	TO-220	TUBE
STW4N150	W4N150	TO-247	TUBE

Table 3: Absolute Maximum ratings

Symbol	Parameter	Value	Unit
V _{DS}	Drain-source Voltage (V _{GS} = 0)	1500	V
V _{DGR}	Drain-gate Voltage (R _{GS} = 20 kΩ)	1500	V
V _{GS}	Gate- source Voltage	± 30	V
I _D	Drain Current (continuous) at T _C = 25°C	4	A
I _D	Drain Current (continuous) at T _C = 100°C	2.5	A
I _{DM} (●)	Drain Current (pulsed)	12	A
P _{TOT}	Total Dissipation at T _C = 25°C	160	W
	Derating Factor	1	W/°C
T _j T _{stg}	Operating Junction Temperature Storage Temperature	-55 to 150	°C

(●) Pulse width limited by safe operating area

(*) Limited only by maximum temperature allowed

Table 4: Thermal Data

		TO-220	TO-247	
R _{thj-case}	Thermal Resistance Junction-case Max	0.78		°C/W
R _{thj-amb}	Thermal Resistance Junction-ambient Max	62.5	50	°C/W

Table 5: Avalanche Characteristics

Symbol	Parameter	Max Value	Unit
I _{AR}	Avalanche Current, Repetitive or Not-Repetitive (pulse width limited by T _j max)	4	A
E _{AS}	Single Pulse Avalanche Energy (starting T _j = 25 °C, I _D = I _{AR} , V _{DD} = 50 V)	350	mJ

ELECTRICAL CHARACTERISTICS (T_{CASE} =25°C UNLESS OTHERWISE SPECIFIED)
Table 6: On /Off

Symbol	Parameter	Test Conditions	Min.	Typ.	Max.	Unit
V _{(BR)DSS}	Drain-source Breakdown Voltage	I _D = 1 mA, V _{GS} = 0	1500			V
I _{DSS}	Zero Gate Voltage Drain Current (V _{GS} = 0)	V _{DS} = Max Rating V _{DS} = Max Rating, T _C = 125°C			10 500	μA μA
I _{GSS}	Gate-body Leakage Current (V _{DS} = 0)	V _{GS} = ± 30 V			± 100	nA
V _{GS(th)}	Gate Threshold Voltage	V _{DS} = V _{GS} , I _D = 250 μA	3	4	5	V
R _{DS(on)}	Static Drain-source On Resistance	V _{GS} = 10 V, I _D = 2 A		5	7	Ω

ELECTRICAL CHARACTERISTICS (CONTINUED)

Table 7: Dynamic

Symbol	Parameter	Test Conditions	Min.	Typ.	Max.	Unit
g_{fs} (1)	Forward Transconductance	$V_{DS} = 30\text{ V}$, $I_D = 2\text{ A}$		3.5		S
C_{iss} C_{oss} C_{rss}	Input Capacitance Output Capacitance Reverse Transfer Capacitance	$V_{DS} = 25\text{ V}$, $f = 1\text{ MHz}$, $V_{GS} = 0$		1300 120 12		pF pF pF
$t_{d(on)}$ t_r $t_{d(off)}$ t_f	Turn-on Delay Time Rise Time Turn-off-Delay Time Fall Time	$V_{DD} = 750\text{ V}$, $I_D = 2\text{ A}$, $R_G = 4.7\ \Omega$, $V_{GS} = 10\text{ V}$ (see Figure 19)		35 30 45 45		ns ns ns ns
Q_g Q_{gs} Q_{gd}	Total Gate Charge Gate-Source Charge Gate-Drain Charge	$V_{DD} = 600\text{ V}$, $I_D = 4\text{ A}$, $V_{GS} = 10\text{ V}$ (see Figure 22)		30 10 9	50	nC nC nC

Table 8: Source Drain Diode

Symbol	Parameter	Test Conditions	Min.	Typ.	Max.	Unit
I_{SD} I_{SDM} (2)	Source-drain Current Source-drain Current (pulsed)				4 12	A A
V_{SD} (1)	Forward On Voltage	$I_{SD} = 4\text{ A}$, $V_{GS} = 0$			2	V
t_{rr} Q_{rr} I_{RRM}	Reverse Recovery Time Reverse Recovery Charge Reverse Recovery Current	$I_{SD} = 4\text{ A}$, $di/dt = 100\text{ A}/\mu\text{s}$ $V_{DD} = 45\text{ V}$ (see Figure 20)		510 3 12		ns μC A
t_{rr} Q_{rr} I_{RRM}	Reverse Recovery Time Reverse Recovery Charge Reverse Recovery Current	$I_{SD} = 4\text{ A}$, $di/dt = 100\text{ A}/\mu\text{s}$ $V_{DD} = 45\text{ V}$, $T_j = 150^\circ\text{C}$ (see Figure 20)		650 4 12.6		ns μC A

(1) Pulsed: Pulse duration = 300 μs , duty cycle 1.5 %.

(2) Pulse width limited by safe operating area.

Figure 3: Safe Operating Area For TO-220

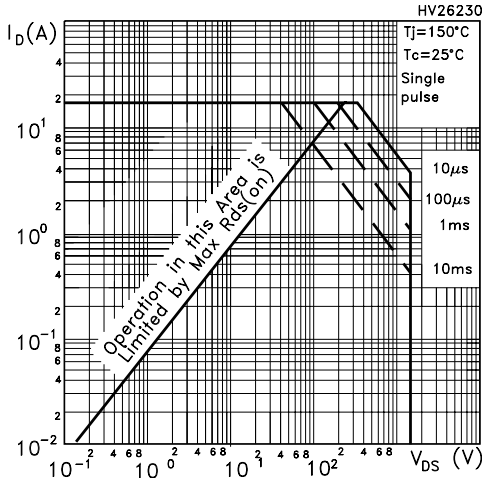

Figure 4: Safe Operating Area For TO-247

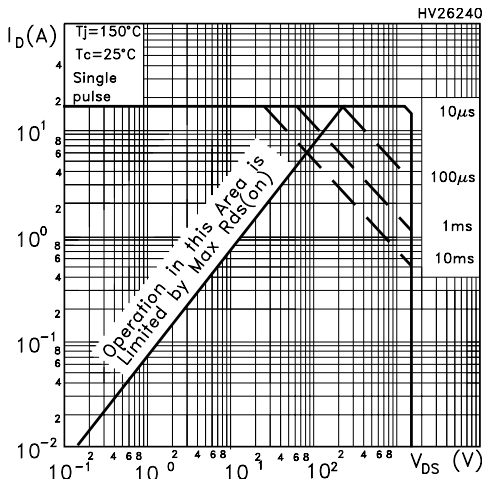

Figure 5: Output Characteristics

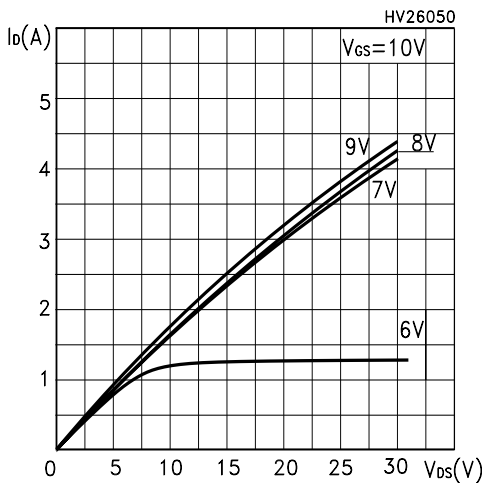

Figure 6: Thermal Impedance For TO-220

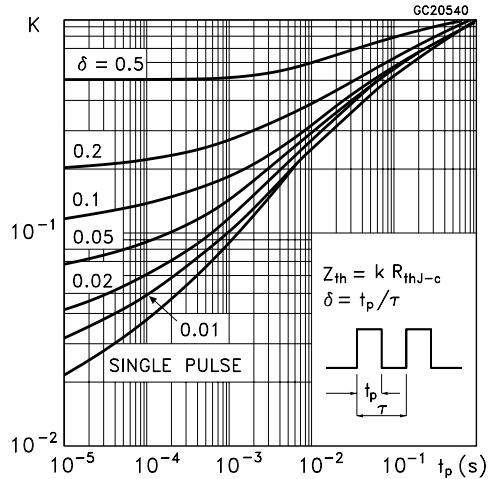

Figure 7: Thermal Impedance For TO-247

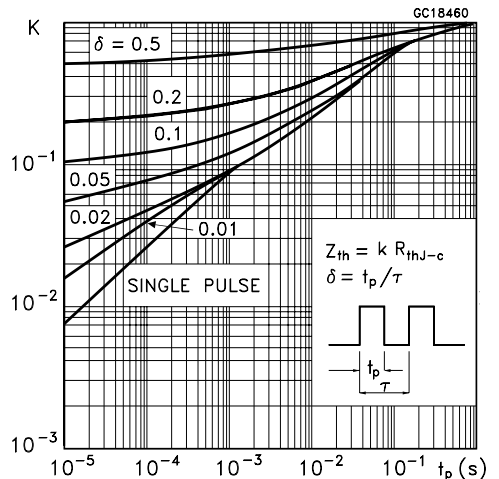

Figure 8: Transfer Characteristics

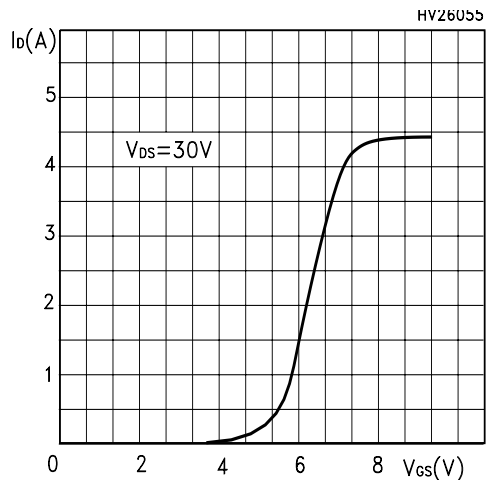

Figure 9: Transconductance

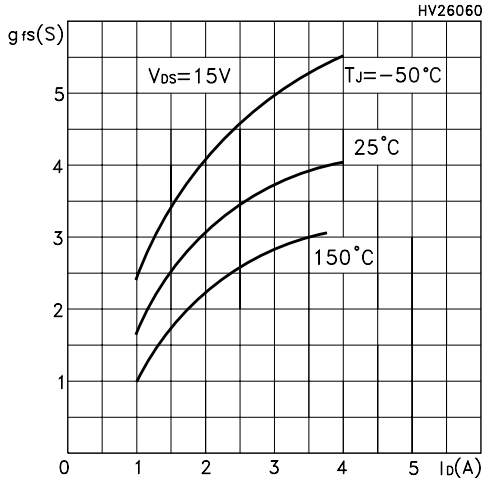

Figure 10: Gate Charge vs Gate-source Voltage

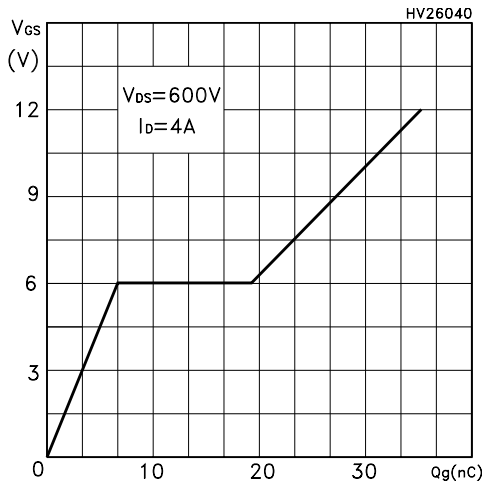

Figure 11: Normalized Gate Threshold Voltage vs Temperature

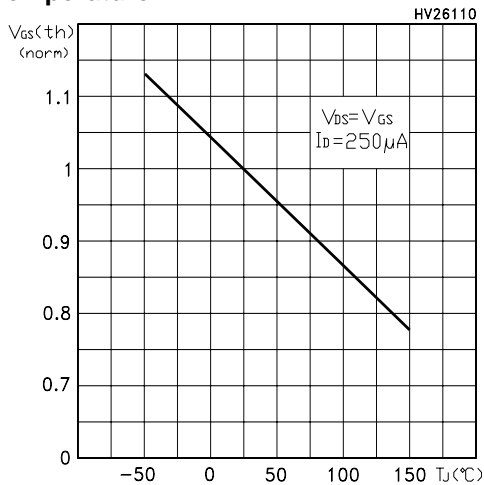

Figure 12: Static Drain-source On Resistance

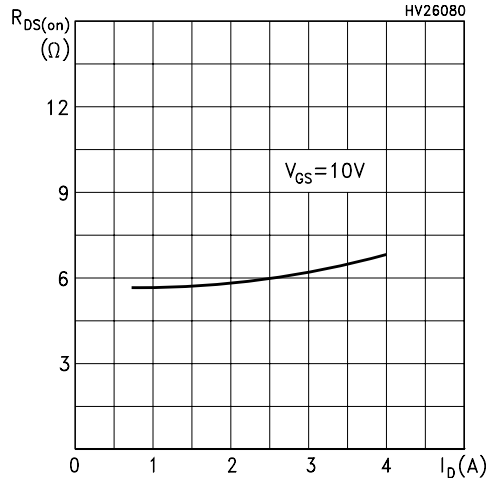

Figure 13: Capacitance Variations

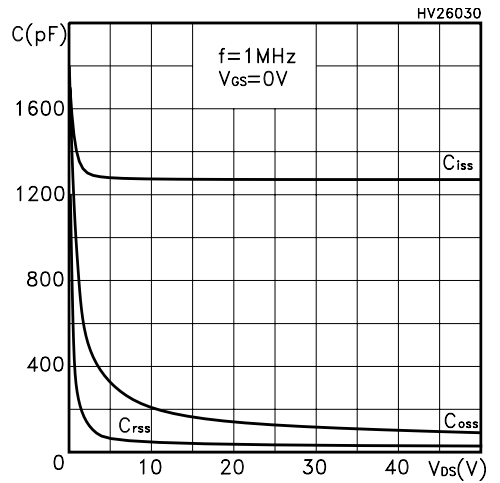

Figure 14: Normalized On Resistance vs Temperature

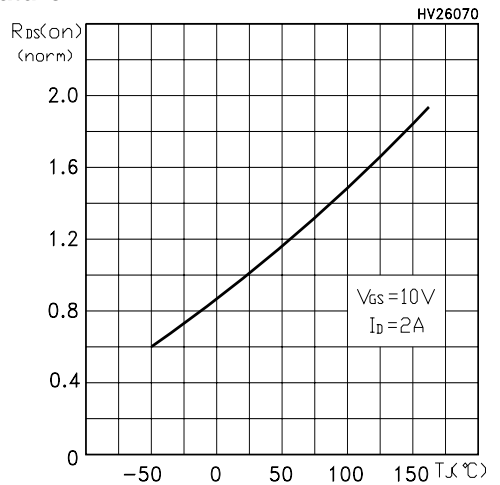

Figure 15: Source-Drain Forward Characteristics

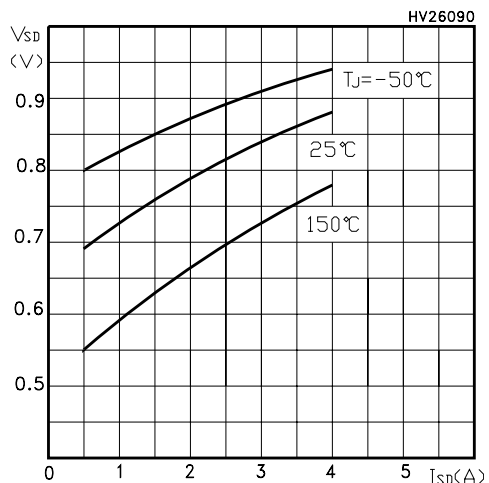

Figure 17: Normalized BV_{DSS} vs Temperature

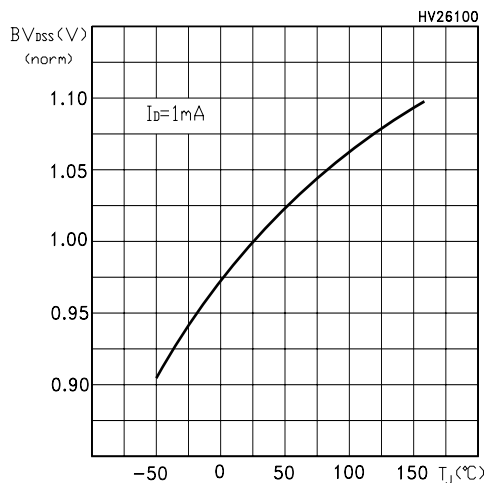

Figure 16: Maximum Avalanche Energy vs Temperature

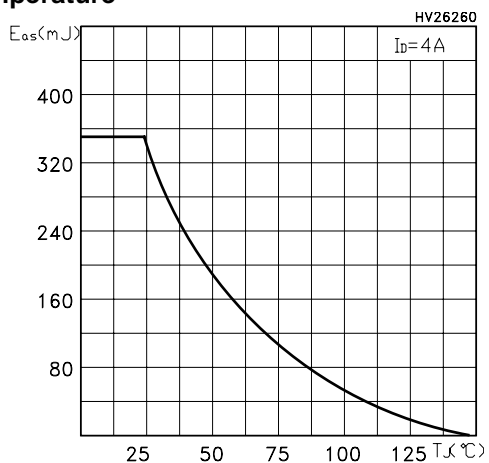

Figure 18: Unclamped Inductive Load Test Circuit

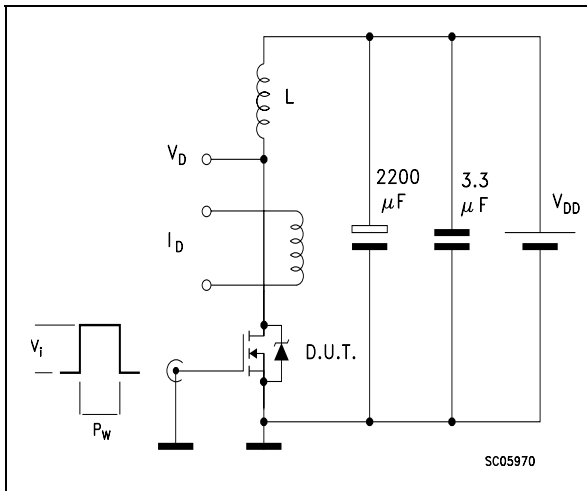

Figure 19: Switching Times Test Circuit For Resistive Load

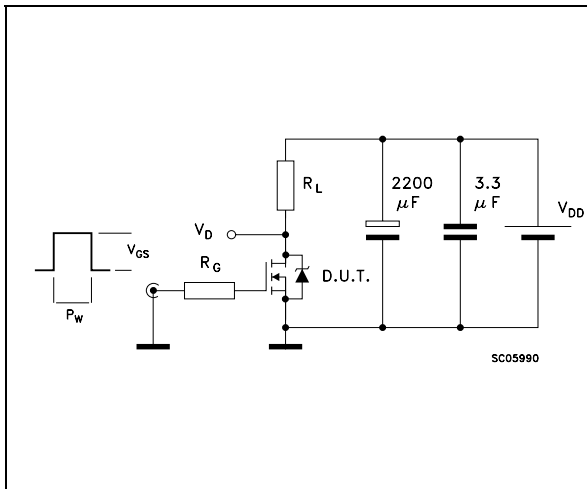

Figure 20: Test Circuit For Inductive Load Switching and Diode Recovery Times

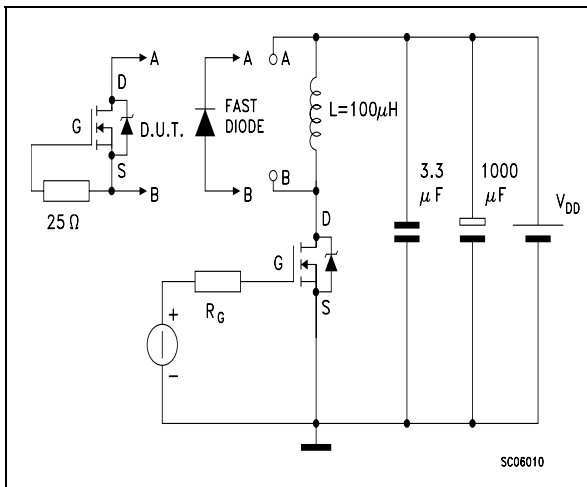

Figure 21: Unclamped Inductive Waveform

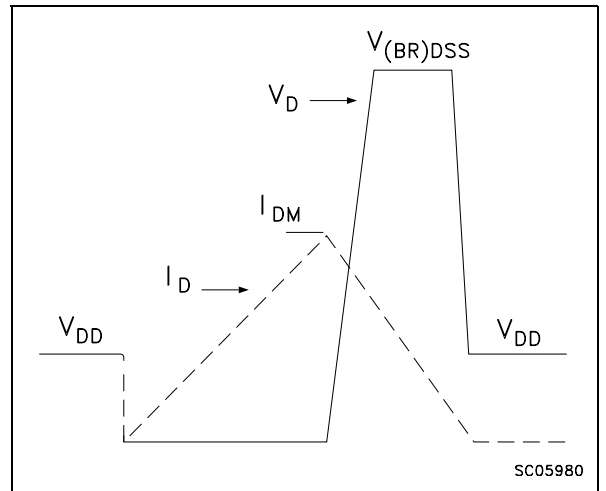
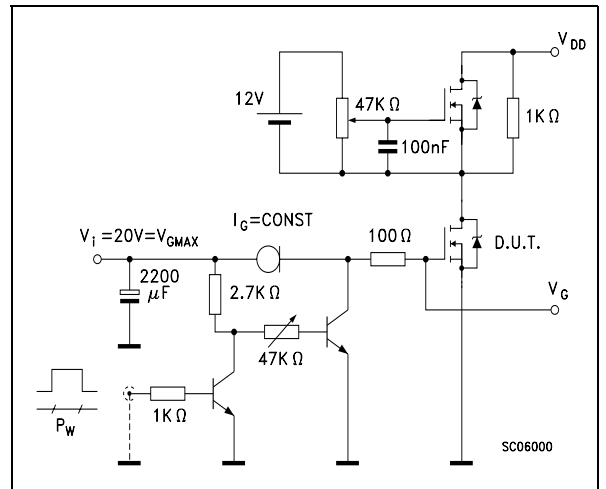
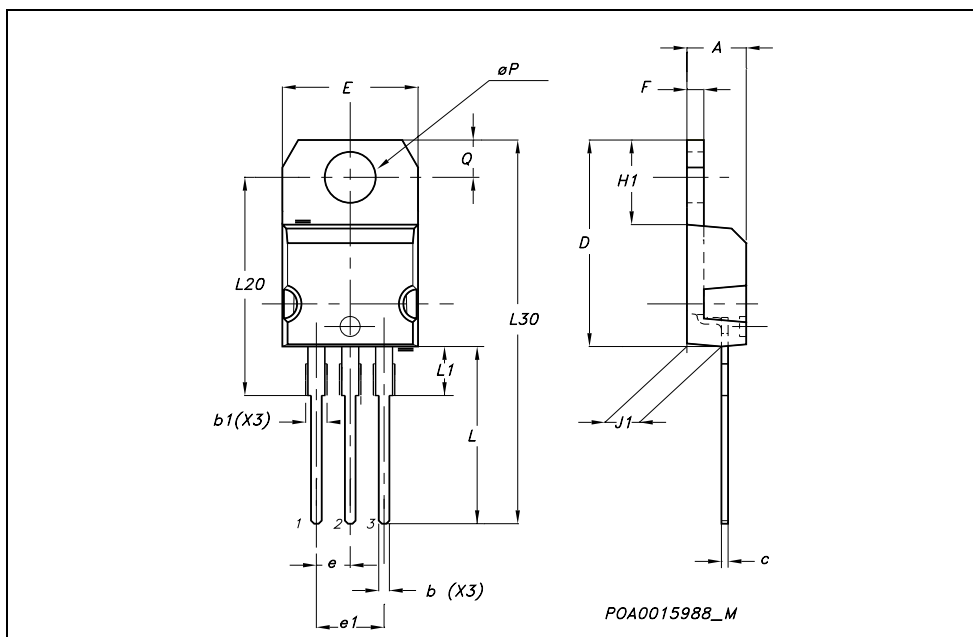

Figure 22: Gate Charge Test Circuit



TO-220 MECHANICAL DATA

DIM.	mm.			inch		
	MIN.	TYP	MAX.	MIN.	TYP.	MAX.
A	4.40		4.60	0.173		0.181
b	0.61		0.88	0.024		0.034
b1	1.15		1.70	0.045		0.066
c	0.49		0.70	0.019		0.027
D	15.25		15.75	0.60		0.620
E	10		10.40	0.393		0.409
e	2.40		2.70	0.094		0.106
e1	4.95		5.15	0.194		0.202
F	1.23		1.32	0.048		0.052
H1	6.20		6.60	0.244		0.256
J1	2.40		2.72	0.094		0.107
L	13		14	0.511		0.551
L1	3.50		3.93	0.137		0.154
L20		16.40			0.645	
L30		28.90			1.137	
øP	3.75		3.85	0.147		0.151
Q	2.65		2.95	0.104		0.116



TO-247 MECHANICAL DATA

DIM.	mm.			inch		
	MIN.	TYP	MAX.	MIN.	TYP.	MAX.
A	4.85		5.15	0.19		0.20
A1	2.20		2.60	0.086		0.102
b	1.0		1.40	0.039		0.055
b1	2.0		2.40	0.079		0.094
b2	3.0		3.40	0.118		0.134
c	0.40		0.80	0.015		0.03
D	19.85		20.15	0.781		0.793
E	15.45		15.75	0.608		0.620
e		5.45			0.214	
L	14.20		14.80	0.560		0.582
L1	3.70		4.30	0.14		0.17
L2		18.50			0.728	
øP	3.55		3.65	0.140		0.143
øR	4.50		5.50	0.177		0.216
S		5.50			0.216	

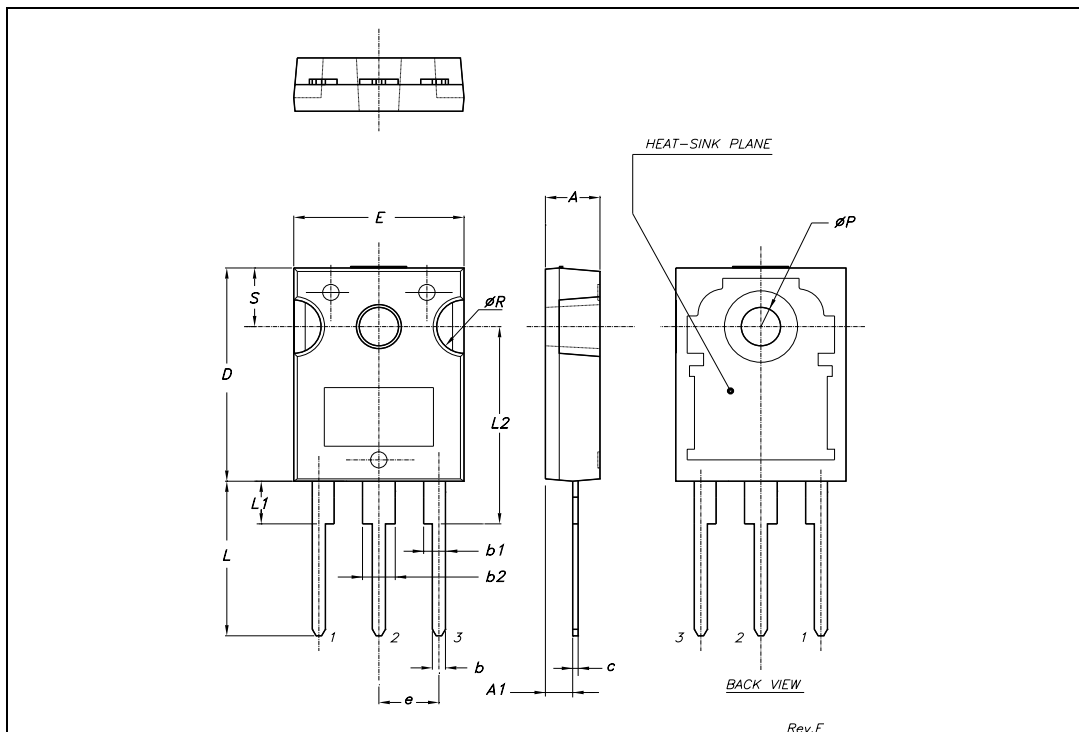

Table 9: Revision History

Date	Revision	Description of Changes
11-Mar-2005	1	First release.
27-Apr-2005	2	Removed TO-220FP
07-Jul-2005	3	Complete version

Information furnished is believed to be accurate and reliable. However, STMicroelectronics assumes no responsibility for the consequences of use of such information nor for any infringement of patents or other rights of third parties which may result from its use. No license is granted by implication or otherwise under any patent or patent rights of STMicroelectronics. Specifications mentioned in this publication are subject to change without notice. This publication supersedes and replaces all information previously supplied. STMicroelectronics products are not authorized for use as critical components in life support devices or systems without express written approval of STMicroelectronics.

The ST logo is a registered trademark of STMicroelectronics

All other names are the property of their respective owners

© 2005 STMicroelectronics - All Rights Reserved

STMicroelectronics group of companies

Australia - Belgium - Brazil - Canada - China - Czech Republic - Finland - France - Germany - Hong Kong - India - Israel - Italy - Japan - Malaysia - Malta - Morocco - Singapore - Spain - Sweden - Switzerland - United Kingdom - United States of America